

WANSARC NEWS

Incorporated in Victoria, 1985 Registration Number: A0007611S

The monthly magazine of the

Western & Northern Suburbs Amateur Radio Club Melbourne, Australia



www.wansarc.org.au

146.450 MHz FM

VK3AWS

28.470 MHz USB

Volume No: 42

Issue 10

October

2011



Next Club Meeting, Friday 7th October Ern Rose Memorial Pavilion, Seaver Grove, Reservoir @ 7.30pm

| Date | UTC-Time | Freq | Mode | RST | ILLW-No | Iota-No |
|------|----------|------|------|-----|---------|---------|
| | | | | | | |
| | | | | | | |
| | | | | | | |
| | | | | | | |
| | | | | | | |

The ILLW contesting is over but the QSL cards still arrive in the mail.

Ours were mailed out instead of the longer wait using the bureau. Trevor VK3ATX designed the cards.

With summer coming it's time to get out the ham gear and go setup in a nice place with a BBQ and cold beer.

There are a few contests on as well, check details at WIA website for rules and times or check AR magazine.

WANSARC members are also invited to come to Rotunda 6, at WANSARC Park (*some folks call it Bundoora Park*) on Saturday 8th from around 10am for a tribute to Bob VK3EL (SK) hosted by Matt VK3ABC. More details page 4.

| | |
|---|----|
| Around the Shack | 2 |
| VK100ARV ~ Celebration of Amateur Radio Victoria 100 Years ~ Roster Request | 5 |
| Coming Events ~ Mark VK3PI | 6 |
| Split Point Lighthouse ~ John VK3FMPB | 8 |
| Shepparton Hamfest Report ~ Mick VK3CH | 9 |
| Orange County ARC, USA ~ Tech Talk - VK3RTV World Wide DATV QSO Party | 10 |
| Why Some Men Have Dogs And Not Wives | 12 |
| WANSARC Club Profile | 12 |



Jamboree on the Air (JOTA) is an annual event in which about 500,000 Scouts and Guides all over the world make contact with each other by means of amateur radio. Radio signals carry their voices to virtually every corner of the world!

The sheer excitement of having a live conversation with a fellow Scout or Guide in another country is the main thing that attracts so many youngsters to this event – JOTA is a real Jamboree during which Scouting experiences are exchanged and ideas are shared. It is a unique opportunity for each individual Scout to get a true feeling of belonging to a worldwide Movement.

The theme of this year's JOTA is "Peace, Environment and Natural Disasters."

12 VOLT PORTABLE TELEVISION



This TV has analogue and DVB reception and receives **VK3RTV** on 446.500MHz direct, no need for a Set Top Box. Altronics, Item **S 8862**, for \$249. Screen width is 9 inches. Perfect for ATV portable, to keep the whole show on 12/13.8v.

FOUNDATION LICENCE WEEKEND

Do you know a relative, friend or anyone interested in becoming a radio amateur? Now is the time for them to act by enrolling in the next Foundation Licence weekend held by Amateur Radio Victoria. Training is available on **September 10 and 11**.

Contact Barry Robinson **VK3PV** 0428 516 001 or email foundation@amateurradio.com.au

It is attracting those who have had some previous hobby radio communications interest (CB, 4WD, Scanner Listener) and others who are attracted to ham radio for the first time.

CENTENARY OF AMATEUR RADIO VICTORIA AWARD



Award purpose:

To mark the occasion of the 100th year of Amateur Radio Victoria there will be an operating award available.

Rules:

Qualification for the award is between August 1 and November 30 and all radio amateurs and shortwave listeners are welcome.

Contact with each member of the state-wide organisation is worth two points. A bonus of ten points, per valid contact, is attainable through:

Contact with **VK3WI** during the Oceania DX Phone Contest (October 1-2). Contact with **VK100ARV** during November, with the special call sign being rostered by members.

A station set-up within a National Park on November 19 & 20 and operating under KRMNPA rules, may claim ten points per contact it logs. Contact with stations who are operating in National Parks only qualify for two points toward this certificate.

Validity: For any contact to be valid it must be on a UTC day or frequency band. That means you are able to make contact with a station only once during a UTC day, unless on another frequency band. For Australian stations a total of 100 points are required and DX stations 25 points.

Claims of an extract of log must be accompanied by \$5 or equivalent and reach the Awards Manager, Amateur Radio Victoria, 40g Victory Boulevard, Ashburton 3147, Victoria, Australia not later than December 6, 2011. ~ARV Website

HEATHKIT MAKING A RETURN

The brand-name that got many into amateur radio is back with a new line of common household products.



The first kit is a Garage Parking Assistant that lets you use ultrasonic sound waves to locate a car as it enters and finally is parked in a garage. The Heathkit website announces that the next product will be a Wireless Swimming Pool Monitor kit followed by many more. It sold amateur radio gear and kits worldwide from 1954 until 1992 and some of the equipment remains in service or as collectables today. With mass production the way ahead, the basic Heathkit business model began to fail, with a kit bringing being fun, but no longer a money saver.

The website is <http://www.heathkit.com/> ~ARV Website

DAYLIGHT SAVINGS STARTS 2nd OCTOBER

Victoria's period of daylight saving will start at 2:00am on Sunday 2 October 2011. At 2:00am standard time (Eastern Standard Time) move clocks forward one hour to 3:00am summer time.

'COOL QSL' ~ GOOD QUALITY & PRICED QSL CARDS

Chris **VK3FY**, had some QSL cards made up ages ago and recommends <http://www.coolqsl.com> for the job. Chris says they are very good. Example cards and full pricing are all on the site.

WANSARC NET

146.450 MHz FM TUESDAY NIGHTS @ 7.30PM
LISTEN FOR NET CONTROL STATION

VK3AWS

MORE GABO ISLAND LIGHTHOUSE (ILLW) PHOTOS
After the successful lighthouse weekend in August, more photos taken by the crew have been given to me.
Some seals on rocks, just about anywhere you looked. ↓



Running repairs done to a fallen antenna (squid pole). ↓



Natural wildlife everywhere. ↓



These were everywhere. ↓



The four main buildings on the island. ↓



The lighthouse lamp, Intensity 30,000 candela power. ↓



Lighthouse staircase, 46.9 meters high. There were just over 200 steps counting the outside stairs up to the front door. The unique staircase has 32 steps between each landing, these are 90 degrees to each other. Unlike most light towers, Gabo is the same internal diameter all the way up. ↓



View of the Gabo Island from the plane. ↓





VK3CH 10GHz / 24GHz ATV PROJECT

Work on the dishes is complete, with very sore fingers from all the fine tolerance metalwork.

Two 10GHz dishes of TX & RX were completed, with the first successful test transmission dish to dish happing at 10am on the 4th October. As the ATV signal will be 7MHz wide, the DX that has been obtained at 10GHz with narrow modes will not happen, but not many 3cm stations in VK are putting up live ATV so it's still unique in its own way.

A steep learning curve in sighting dishes and getting used to the propagation of the 3cm band will keep Mick busy for many months, maybe years...

ATV should go (line of sight) across most of metropolitan area. 24GHz analogue ATV gear still being built up as well, once results and testing a "show and tell" to the club will be in order.

~Mick VK3CH

VK3 MICROWAVE ACTIVITY DAY

On Sunday, 16 October stations from VK3 will turn out for the 1296 MHz show down as a test of capability. This follows the successful activities over the last two Easter's.

It will be spearheaded by Michael Coleman VK3KH, perched portable at Arthur's Seat on the Mornington Peninsula, who welcomes visitors.

He says any radio amateur with 23 cm capability is welcome to take part in the event. The band is the easiest in the microwave spectrum whether home-based or portable.

Activity will start at 0830 (AEDT) which is 2130z. The first hour and a half to focus on 1296 MHz concentrating at 1296.150 MHz SSB, then progressing to the other bands. Liaison will occur on 144.150 MHz

Michael VK3KH at mdc@cranbournemusic.com.au

~ARV Website

*Remembrance Tribute
Bob VK3EL (SK)
QSO & BBQ
Rotunda 6
Bundoora Park
Saturday 8th October
10am ~ 2pm*



As a tribute to the anniversary of the passing of Bob, VK3EL, Matt Stanton, VK3ABC, will be setting up some of Bob's old transceivers at the park and invites WANSARC members to have a QSO and an informal get together to remember Bob and catch up with everyone from WANSARC.

Some BBQ food and salads will be available, but we request numbers planning to attend for catering purposes.

If you are unable to attend we would still like to chat to you on the air, 146.450MHz, listen for VK3EL callsign.

Darebin gets ready for Wi-Fi trial

Darebin Council will support residents and businesses in Reservoir to access affordable, wireless internet options as part of an innovative pilot project involving Infoxchange Australia. The pilot project will provide WiFi in both the shops and open areas of the shopping strips at Broadway and Edwardes Street in Reservoir. The project will also provide nearby residents with affordable broadband to use in their homes.



The broad vision for the WiFi pilot project is for Darebin Council to extend the wireless internet access to Preston and Northcote shopping precincts and nearby homes, benefitting the community, traders and businesses, and placing Darebin at the leading edge of online digital access in Australia. Darebin Council's WiFi pilot project will also seek to respond to Darebin's digital divide. Over 40% of residents in Darebin do not have access to any internet connection, which significantly reduces their access to information, social networks, and opportunities for work and leisure interests.

Students, job seekers, pensioners and members of new and emerging communities are expected to greatly benefit from the outcomes of the Darebin WiFi pilot project. The project will also involve sourcing refurbished affordable computers through Infoxchange Australia's Green Personal Computer program to support residents without computers to access the WiFi network.

For more information about the WiFi pilot project contact Darebin City Council on 8470 8888 or go to www.darebin.vic.gov.au

VK100ARV ~ Celebration of Amateur Radio Victoria 100 Years

As mentioned last club meeting **WANSARC** will be operating as a special event station using the special event call sign of **VK100ARV**.

WANSARC as a club have custody of **VK100ARV** in November from;

| | | |
|-------------------|---------------------|---|
| 00:00 ~ 23.59 UTC | 5th (UTC) Saturday | (11am Saturday until 10.59 am Sunday Local Time) |
| 00:00 ~ 23.59 UTC | 6th (UTC) Sunday | (11am Sunday until 10.59 am Monday Local Time) |
| 00:00 ~ 23.59 UTC | 7th (UTC) Monday | (11am Monday until 10.59 am Tuesday Local Time) |
| 00:00 ~ 23.59 UTC | 8th (UTC) Tuesday | (11am Tuesday until 10.59 am Wednesday Local Time) |
| 00:00 ~ 23.59 UTC | 9th (UTC) Wednesday | (11am Wednesday until 10.59 am Thursday Local Time) |

It is proposed to have club members set up at Bundoora Park on the weekend as a multi-operator station on as many bands as we can get. At other times individual club members can operate as **VK100ARV** either from home or portable, provided they operate from the same fixed location for the duration of their time period.

Without VK100ARV being under the direct supervision of an Advance Licence, it MUST always be operated according to the person's qualification.

If you would like to operate as **VK100ARV** either from the park or from home, you need to see or contact Mick VK3CH, to have your name put down on the roster which will be given to Amateur Radio Victoria, to place on their website so stations after 10 points for contacting special event call **VK100ARV** know where to find us, both locations and operating frequencies.

Mick will have a roster to fill out, so if you're interested, please get your name on the roster.

But be warned, your making a commitment to be on air on as many frequencies you can comfortably do.

You can apply one hour or two or three, or half a day, it's up to you, but please use your time being on air!!

If there are clashes for certain times, then it's either first in best dressed, or "plead your case!"

This event is both for local, DX and international DX, so any night owls that run HF late into the night; here is your chance to become a "rare one".

Full information, rules and conditions are at <http://www.amateurradio.com.au/awards>

Take a read and then apply to have a time block with **VK100ARV**, multiple blocks are on offer if you wish.

Apart from weekend during daylight hours, or during Tuesday night WANSARC NET, all other times are open. So see Mick VK3CH this Friday, or email him at vk3ch@wia.org.au to request a time slot.

COMING EVENTS from Mark VK3PI

JAMBOREE OF THE AIR (JOTA) 2011

The club station of WANSARC, VK3AWS, will again be heard in 2011 supporting the West Metropolitan Girl Guides Region JOTA at Hoppers Crossing.

Last year a small but dedicated team of 4 operated on VHF and HF with 60+ girl guides taking the opportunity to share their experiences via radio with other girl guides and scouts.

This year the club will operate on **Saturday, October 15, 2011**, marshalling at the Hoppers Crossing Guide Hall around 0900 for operations commencing around 1100 hours.



If you are able to spare some time, equipment and antennae, please contact Mark VK3PI at the next club meeting, via email at vk3pi@optusnet.com.au or leave a message on my mobile 0425 768 320.

Club member John VK3FMPB is intending to operate from Riddells Creek during JOTA, as he has done for many years. Ian VK3JQ normally steers the Riddells Creek ship but will not be available this year, so John is seeking some assistance for the weekend of October 15-16, 2011. If any member is available to assist please contact John VK3FMPB at the next club meeting or send your details to the club secretary at vk3pi@optusnet.com.au

Incidentally Australian JOTA calling frequencies are 3.650, 7.090, 14.1980, 21.190, 28.590, 52.160. VHF will also be used and VK3AWS will be heard on the club frequented frequency of 146.450MHz FM.

WANSARC CHRISTMAS DINNER

Where has the year gone? Christmas is just around the corner so it is appropriate that the club consider its options for Christmas dinner.

At the most recent WANSARC Committee meeting it was decided to investigate the club's Christmas dinner options.

Two options have been investigated for consideration by club members.

One option is to have the Christmas dinner at our club rooms on **Friday evening, December 2, 2011**, using the same company as last year (Christy's) to provide a spit roast choice of three meats (Beef-Pork-Lamb-Ham-Chicken), hot potatoes, fresh

salads, sweets. Condiments, fruit platter and tea/coffee. Approximate cost per person will be \$21 based on a minimum of 40 people attending.

Trevor VK3ATX has offered an alternate solution with the venue the Darebin RSL in Bell Street, Preston. The date available for the dinner is **Saturday, December 10, 2011** with a range of meals available including porterhouse steak, chicken breast Tasmania and roasted pork cutlet. All main meals are served with mixed seasonal vegetables and salad on request. Costs per person for a 2 course meal is \$25 and a three course meal \$32.50. A mini-buffet meal is also available for \$32.50.

Members will need to make a decision on their preferences for Christmas dinner very quickly, so if you are attending the next club meeting please consider your preference for Christmas dinner and cast your vote in person. If you will not be attending the next club meeting please provide your choice of venue to the Secretary at yk3pi@optusnet.com.au or leave a message on mobile 0425 768 320 prior to the club meeting.

PUPPETS IN DEMAND



Darebin Council has advised that the WANSARC club rooms will be used by Council's Arts and Cultural Unit between **September 26 and October 7, 2011**.

The Arts and Cultural Unit will be creating life size puppets between the hours of 9am to 5pm Monday to Friday.

Puppet artist Daniele Poidomani will be hosting a series of workshops under the banner of the "Bigger Picture Puppet Project".

The puppets will be stored at the boathouse, more than likely in one of the change rooms.

Council has asked that the puppets not be handled by club members.

The puppets will be unveiled at the **Festival of Light and Friendship** on Sunday 30 October at Edwardes Park Lake.

Mark in your 2012 diary the **WANSARC FAMILY DAY**, to be held on **Sunday January 22, 2012**. As usual the venue will be Bundoora Park. Further details will be provided closer to the event however as per previous events financial members of the club and their immediate families will enjoy a free BBQ lunch, soft drinks, salads, bread and some sweets. So mark this date in your diary now as the first club event for 2012.

Split Point Lighthouse ~ John VK3FMPB

This is the day of reckoning, the day I either make or break my reputation as a radio operator. The day I get to inhabit the Split Point lighthouse at Aireys Inlet way out West Victoria past Geelong and about half an hour or so drive past Torquay and I'll be on my own.

The history of the ILLW goes back to 1993 when a couple of blokes, hams, the late Mike GM4OOU and his mate John GM4SUC were having a chat after a club meeting of the Ayr ARC in Scotland and decide to start a weekend where they could not only get out and play radio but also have a theme and maybe even educate people a little. Not having known anything about lighthouses prior to this event it sure has worked on me.

I was pretty lucky in being able to secure this particular building as the GARC usually use it. I had emailed them previously and we had set up a tentative arrangement where I would tag along on their day. When I wrote later to confirm our previous arrangement they told me they wouldn't be there this year so I had the place to myself. A couple of quick trips between Aireys Inlet and the info centre near the beach was all it needed to formalise the deal. Eco logic, the group who run the lighthouse were extremely helpful and friendly and even offered me the site on my own. Notwithstanding the usual tours that a lovely young girl named Mel runs of the place. I even saw a couple of large signs on the office relating to the ILLW. I wondered if I would have many visitors to the site on the day. Better put my best diplomatic demeanour on just in case.

With an elevation of 66m and a building height of 34m I should be in a good position to hear one and all I hope.

I intended to run VHF and HF although my main band was HF. I had VHF just to see what I could hear. who knows, I might even get Tasmania on simplex if I'm lucky.

I set my radio up on my table just outside the lighthouse in the car park of which there were only two spaces. On my table was my radio (706), power supply, log book drink bottle. VHF antenna lashed to a parking sign and the balun and wire lashed to the parking sign on the other side. The antenna was thrown 34m in the air and lashed to the railing on top of the lighthouse so I was expecting goods things. Ah but it just wasn't to be.

I tried and tried but I thought my 706 was deaf. So I changed baluns and tried again. A little better but could still only raise about 3 or 4 stations. Trevor VK3ATX at Gabo Island being one of them. I could hear numerous stations talking including Terry VK3UP with the WIA at Williamstown time-ball tower but he just didn't seem able to hear me. That seemed to happen a lot. I heard stations that ATX and UP were talking to in Adelaide or NSW but was unable to raise them sadly. However, that is not to say I wasn't busy. I had tourists by the dozen coming to the lighthouse, mostly overseas uni students from what I could gather, and most of them enquired of me what I was doing. Some even made a connection between Ham radio and CB radio, "Oh I had a CB years ago, is it the same?" Not quite I would say and explain about how we potentially had millions of channels compared to 40 on the CB. A few photos were taken of my station which I hope to RX in the email soon. I met a US ham who told me his call but I didn't write it down. That was how the day went. Few contacts on the radio but many in the flesh so to speak. That's when the fun began. I hadn't been using the car battery at all so I don't know what caused it to fail in the middle of the Geelong rd servo I went to but it did. That was 5 minutes down the road out of Geelong.

I bought a set of jumper leads but the car kicked over ten minutes later by chance. I got to my local shops in Racecourse Rd. Flemington and it happened again. Once again it kicked over ten minutes later on its own and I got it home. Then it died again in my garage. So I called the RACV and it magically started again. I was getting sick of it by now. I went for a drive to Williamstown to see if they were still there and it happened again. Will I just not learn? Luckily I bumped into Wayne VK3VCL and daughter Lilly at the lighthouse. Wayne looked at the battery and cleaned it up a bit with some of Terry VK3UP's magic water and it started again as if by that same magic. I took it straight home and after consultation with Ford will have the car towed to Essendon Ford for a new battery.

Ah the price we pay for our hobbies.

I'm already working on a design for a multi band dipole set up on a round bit of aluminium tubing using an antenna switch for next year which hopefully will go around the top of the lighthouse.

My, this is an addictive little hobby isn't it?

Cheers Johnno VK3FMPB



Shepparton Hamfest Report ~ Mick VK3CH

After saying my selling days are done, a few more items were found to dispose of, so a table was booked and another trip to Shepparton done, with Trevor **VK3ATX** coming along with some of his stuff as well. Numbers seemed a little down and the economic situation made for slow selling, but sell we still did, collecting just shy of \$1800, so worth doing, helps pay for the new microwave gear! Five WANSARC members were seen wandering about, but no photos as I had to stay at my table. Sold most of my stuff and bought *nothing* at the Hamfest, only thing that I was after, being hardline coax, was not on sale. Hamfest food looked very good, but too busy to get any, but a feed at the local Shepparton pub was very good; lots of it and well priced. ~ Mick VK3CH



Sellers setting up before opening time ↑

↓ Ross, Strictly Ham, eats a ham sandwich as he sets up his stall



↓ Mick VK3CH / Trevor VK3ATX table of stuff on sale ↓

"Buy something and no one gets hurt, OK?"



This is the newsletter of The Orange County Amateur Radio Club, USA ~ Tech Talk 95 - with their article on the recent VK3RTV World Wide DATV QSO Party.

TechTalk95
The VK3RTV World-Wide
DATV QSO Party
 by Ken Konechy W6HHC

In celebration of the 100 Years of Amateur Radio Victoria providing support for ham radio, organizer Peter Cossins VK3BFG and the hams associated with the VK3RTV digital-ATV repeater conducted the first world-wide DATV QSO Party on August 26-27 (UTC). The VK3RTV repeater is the first in Australia with a two channel multiplexed 100%-digital-transmitting output. In eastern Australia, many hams had contact directly line-of-sight by radio frequencies with the VK3RTV DATV-repeater (near Melbourne). In other parts of Australia, and Thailand, and United States, hams relayed their video to Peter VK3BFG by SKYPE video-connections...who then uplinked the video and audio to the VK3RTV digital repeater using the DVB-S protocol for DATV.

Getting a 1.2 GHz DATV Signal to Australia

The W6HHC digital-ATV signal was transmitted on 1.2 GHz using DVB-S protocol for DATV. The signal was then received on a nearby satellite-SetTopBox receiver that sent the video signal over by USB to a Dell notebook computer to be displayed. See Fig 1 of the W6HHC DATV video being received in Orange, CA.

The next step was to take the video display on the notebook computer and send it over the internet by SKYPE video-connection (called "shared-display" or "shared-desktop") to Peter VK3BFG, the net control station for the DATV QSO Party. See Fig 2 for a block diagram explaining the video signal path. Peter



Figure 1 – W6HHC 1.2 GHz DATV Video being Received on SetTopBox/Notebook-Computer

VK3BFG then uplinked the received SKYPE video to the VK3RTV DATV repeater on 1.2 GHz using DVB-S protocol. The VK3RTV repeater in turn downlinked W6HHC video on 446.5 MHz using the DVB-T protocol.

As shown in Fig 2, a 5.8 GHz link direct from the VK3RTV repeater site to an internet gateway sends the video over internet as streaming video to the BATC (British Amateur Television Club) server. Now the VK3RTV video could be seen all over the world through the www.BATC.TV/ internet URL. It was exciting to watch my DATV video come back from the VK3RTV digital-repeater via the BATC streaming server on the internet. This was an interesting combination of ham radio and internet!

Getting my DATV Signal to Australia via W6ATN

Amateur Television Network (ATN) links several ATV repeaters in California-Arizona-NV-NM including W6ATN located on Saddleback Peak in Orange County.

Figure 2 – Block Diagram Showing W6HHC DATV QSO Straight to Australia

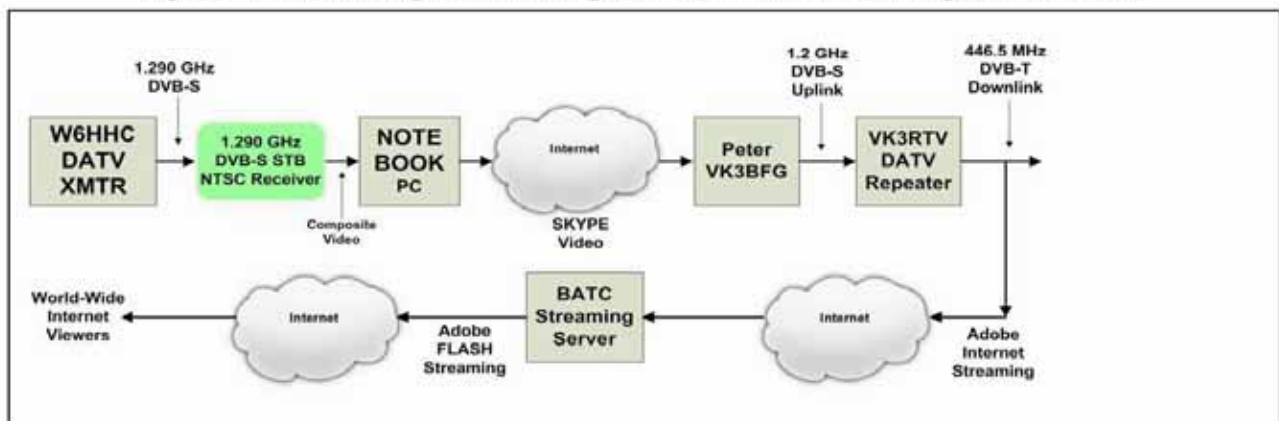
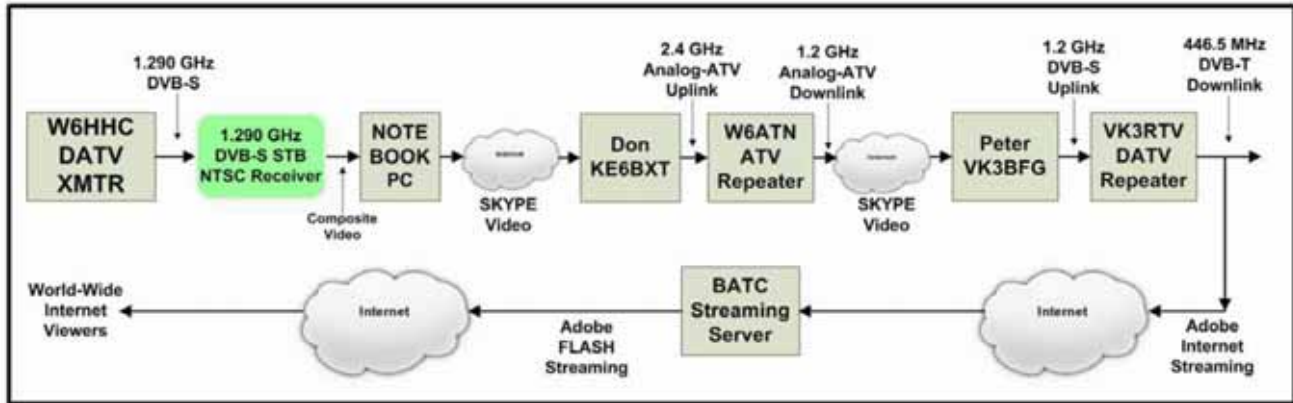

Figure 3 – Block Diagram Showing W6HHC DATV QSO to Australia via W6ATN



Don KE6BXT in Mission Viejo worked very closely with Peter VK3BFG while planning for the DATV QSO Party to allow ATV hams in the US to uplink to W6ATN and then send the W6ATN repeater video to be sent to VK3BFG over the internet using SKYPE video-connection. Don KE6BXT also allowed me to SKYPE my DATV video directly to him. KE6BXT then uplinked my signal to W6ATN on 2.4 GHz and then SKYPE'd the 1.2 GHz ATV downlink to VK3BFG via a separate SKYPE video-connection. **Fig 3** has video path details.



Figure 5 – The Larger Picture is Peter VK3BFG testing with Don KE6BXT (smaller PIX in lower corner) (photo courtesy of KE6BXT)



Fig 4 – Typical VK3RTV Repeater Test Pattern seen over the Internet

Summary

The VK3RTV world-wide DATV QSO Party was a success! Peter VK3BFG reported that he logged a total of 65 QSO's during the DATV QSO Party event, including three VK3 portable DATV stations operating in the field for the event.

Don KE6BXT reported that 16 different US hams checked into (by RF or by SKYPE-video) the VK3RTV DATV QSO Party via ATN. As said earlier, I thought this QSO Party was really an interesting and exciting inter-mixing of digital-ATV, analog-ATV and internet. My only disappointment was that I could not watch the BATC streaming video on my iPad. This small compatibility glitch was caused by Apple refusing to support FLASH-video on the iPad or iPhone. I want to thank Don KE6BXT for helping me sort out a dozen SKYPE issues before the QSO Party and Peter VK3BFG who took the time to test with Don and me using SKYPE before the QSO Party. The DATV QSO Party was great fun!! I got to meet (see) a lot of DATV hams. I think this event was great promotion of DATV!!

Interesting DATV Links

- VK3RTV Digital Repeater WEB site – see www.VK3RTV.com
- W6ATN Amateur Television Network (ATN) – see ATN-TV.org/
- Amateur Radio Victoria organization – see www.AmateurRadio.com.au/
- British ATV Club - Digital Forum – see www.BATC.org.UK/forum/
- British ATV Club – select from about 25 streaming repeaters – see www.BATC.TV/
- German ATV portal for streaming repeaters and forum – see www.D-ATV.net/
- Orange County ARC newsletter entire series of DATV articles – see www.W6ZE.org/DATV/
- Yahoo Group for Digital ATV – see groups.yahoo.com/group/DigitalATV/

Why Some Men Have Dogs And Not Wives:

1. The later you are, the more excited your dogs are to see you.
2. Dogs don't notice if you call them by another dog's name.
3. Dogs like it if you leave a lot of things on the floor.
4. A dog's parents never visit.
5. Dogs agree that you have to raise your voice to get your point across.
6. You never have to wait for a dog; they're ready to go 24 hours a day.
7. Dogs find you amusing when you're drunk.
8. Dogs like to go hunting, fishing and don't mind spending the whole day with you while you work DX.
9. A dog will not wake you up at night to ask, "If I died, would you get another dog?"
10. If a dog has babies, you can put an ad in the paper and give them away.
11. A dog will let you put a studded collar on it without calling you a pervert.
12. If a dog smells another dog on you, they don't get mad. They just think it's interesting.
13. Dogs like to ride in the back of a pickup truck and don't care how much money you have.

*To test this theory:
Lock your wife and your dog in the garage for an hour.
Then open it and see who's happiest to see you.*

WANSARC VK3AWS

PRESIDENT: Graeme McDiarmid VK3NE vk3ne@wia.org.au

SECRETARY: Mark Stephenson VK3PI Telephone: 0425 768 320 vk3pi@optusnet.com.au

All correspondence to be addressed to the **SECRETARY: PO Box 336, RESERVOIR 3073**

WANSARC CLUB PROFILE

History

The Western and Northern Suburbs Amateur Radio Club (**WANSARC**) was first formed in 1969 and since then has served the needs and interests of amateur radio operators, short wave listeners and those interested in hobby radio and electronics. The club is not gender specific, having both female and male members. Members come from all walks of life with a mix of experience, young and mature, novice and technical. The most important aspect of the club is the willingness of all members to share their knowledge for the benefit of others. Members mainly reside in the west and north of Melbourne; however membership is encouraged from all interested. **WANSARC** is an affiliated club of **The Wireless Institute of Australia**.

Meetings

Meetings held at the **Ern Rose Memorial Pavilion, SEAVER GROVE, RESERVOIR** (Melway Map 18 D5) on the **1st Friday of each month** (excluding January) commencing at **7.30pm local time**. Talk in on **146.450MHz FM**—call club station **VK3AWS**.

Benefits

Free technology and related presentations, sponsored construction activities, discounted (and sometimes free) equipment, network of likeminded radio and electronics enthusiasts, excellent club facilities and environment plus an informative monthly newsletter for members to post articles, news, classifieds for all radio, test equipment, etc, featuring Amateur Radio news from WANSARC, ARV, WIA, ACMA, Melbourne Clubs, VK and Worldwide.

Club Nets

146.450MHz FM each Tuesday evening commencing 7.30pm local time.

Website: www.wansarc.org.au

Postal: **WANSARC PO Box 336 RESERVOIR 3073**

A proud tradition of supporting hobby radio and electronics enthusiasts since 1969

All editors' comments and other opinions in submitted articles may not always represent the opinions of the committee or the members of **WANSARC**, but are published in the spirit in which they were submitted; in any case anything stated is to promote interest and active discussion on club activities and the promotion of Amateur Radio in general. Contributions to **WANSARC** are always welcome from any part of the world. Email attachments of Word™, Plain Text, Excel™, PDF™ and JPG are all acceptable. You can either post material to the Post Office Box address at the top of this page, or email your submission to the editor direct at vk3ch@wia.org.au

Email attachments not to exceed 5 Mb in file size. Attachments of (or thought to be) executable code or virulently affected emails will not be opened.

Other persons or radio clubs may edit or copy out such as they like from the magazine but a reference to **WANSARC** is appreciated, except copyrighted (©) material or as otherwise indicated. Other articles that are credited to outside sources should be asked for their permission if they are used.

While we strive to be accurate, no responsibility taken for errors, omissions, or other perceived deficiencies, in respect of information contained in technical or other articles.

Any dates, times and locations given for upcoming events should always be checked with a reliable source closer to the event – coming up on the **WANSARC Tuesday evening NET** on **146.450 MHz** starting at **07:30 pm Local** is recommended to discuss and confirm information and any dates.

The club website has current information on planned events and scheduled meeting dates. **WANSARC** News written with Word™ 2007, published with Adobe Acrobat™ 10.